

Protecting your hydrogen-cooled generator since 1932

LECTRODRYER

adsorption technology experts since 1932

BAC-50 HYDROGEN DRYER

Humidity Presence is
Inevitable in Hydrogen
Cooled Generators:

Enhance Purity and Hydrogen
Safety with Lectrodryer
BAC-50 Hydrogen Dryer

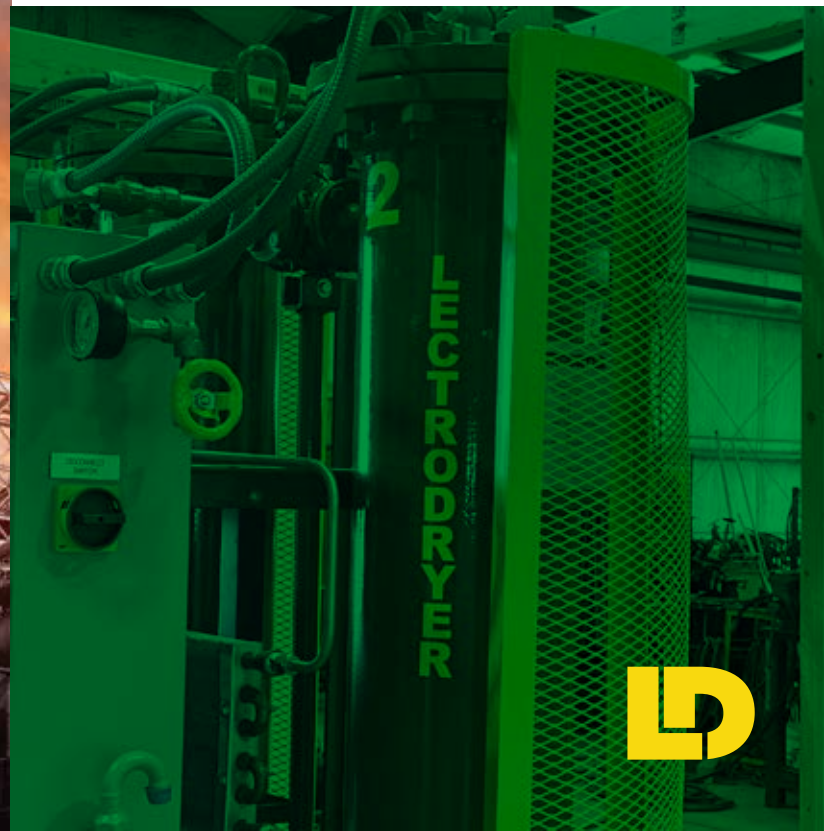
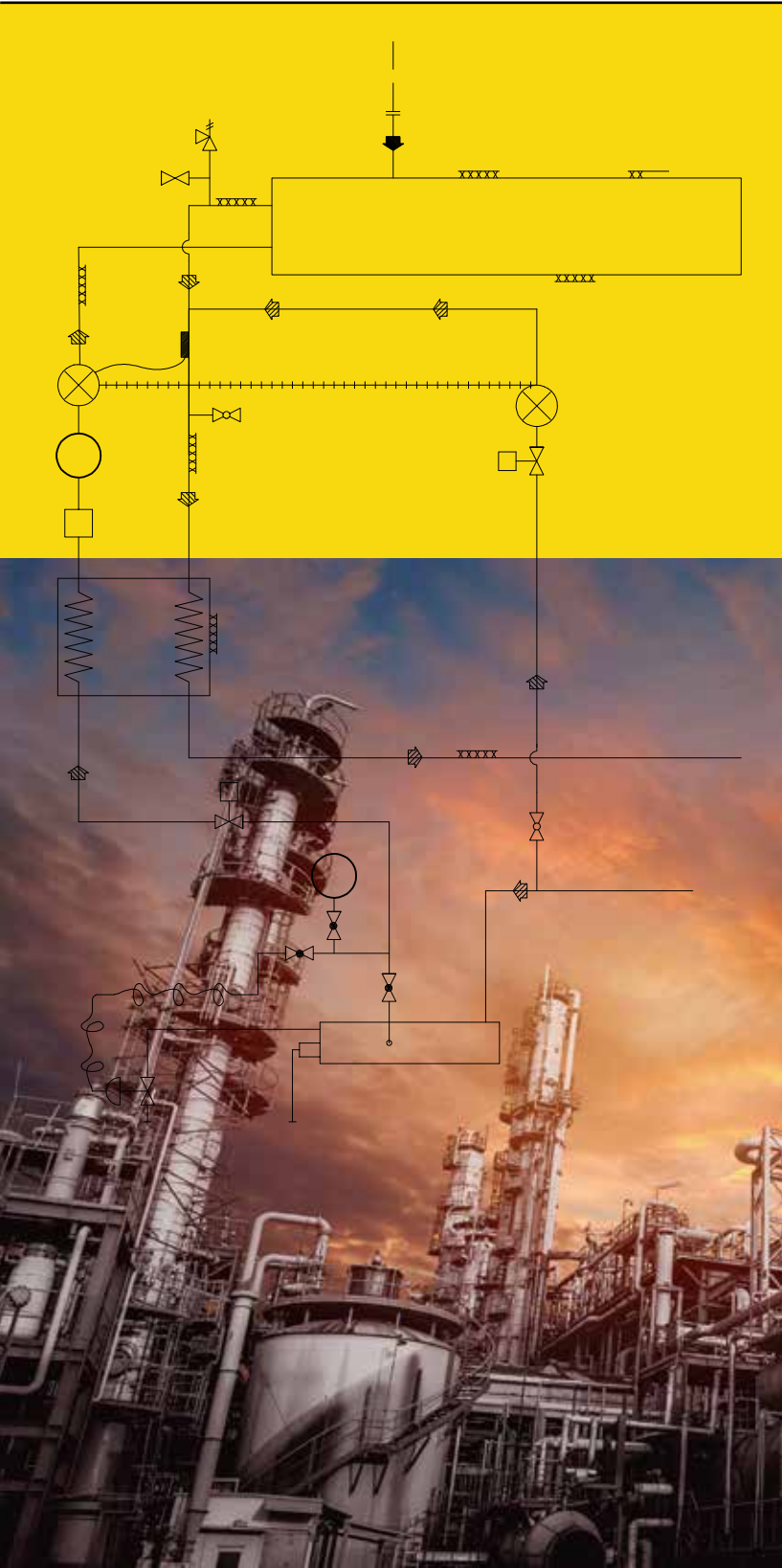

BAC-50 HYDROGEN DRYER

Automatic Regeneration • Increased Purity • Hydrogen Safety • Removed • Water Measurement



Improve Generator Protection

Moisture attacks the generator by: Damaging the generator insulation, creating hotspots, rapidly propagating stress corrosion cracking in retaining rings and reducing hydrogen purity and generator cooling.

Increase Hydrogen Purity

Humidity is not tracked by hydrogen purity analyzers and it decreases your hydrogen purity. Know your true hydrogen purity by having an accurate dewpoint while drying and protecting your generator.

Hydrogen Safety

No additional hydrogen handling since no hydrogen venting or purging is necessary for reactivation. Hydrogen is boosted by internal blower avoiding the need of a positive displacement blower.

Engineered For Upset Conditions

Protected dewpoint sampling cell to avoid contamination and provide an accurate dewpoint. The system is designed to discharge liquid water and oil that may drain through hydrogen piping. Desiccant used has the highest humidity adsorption rate for the application and system is oversized to remove excess humidity fast.

Easily Pays For Itself

Increase Heat Rate efficiency thanks to a higher cooling capability and reduced windage losses caused by moisture presence. No operator involvement required for regeneration. Hydrogen replacement and handling to maintain purity is significantly reduced, promoting safety and ongoing savings. The prevention of just one moisture caused outage will more than pay for the cost of the BAC-50.



BAC-50 HYDROGEN DRYER

Introduction

The BAC-50 provides total dewpoint control and guards against damage causing moisture which can lead to costly repairs, down time, and losses in efficiency. When operating or offline (turning gear), drying remains constant. The regeneration chore is eliminated. The Lectrodryer BAC-50 does it all for you, automatically and without operator involvement.



Description

The BAC-50 Lectrodryer is an automatic dual tower unit for the continuous drying of hydrogen gas used in cooling turbine generators. The unit utilizes regenerative type desiccant and is fully automatic in operation. The BAC-50 is used worldwide and can meet all known specifications including ASME, PED/ ATEX and IECEx with certified components (IECEx certified assembly available as an option upon request). The BAC-50 is heat reactivated with high efficiency embedded electric heaters, and overtemperature protection. It can operate from seven standard voltages, and has NEMA 4 purged electrical enclosures to meet Hazardous Area Classification Cl 1, Div 2, Gr B or IIBG, IIC, T4 for Zone 2.

The BAC-50 allows the continuous monitoring of the volume of water removed from the generator. The BAC-50 Lectrodryer generates an adsorption flow and a reactivation flow simultaneously. Flow can be continued through the generator and dryer even though the turbine may be on turning gear.

The BAC-50 Lectrodryer features ASME or PED carbon steel pressure vessels with embedded electric heater and flow booster in each adsorber vessel, initial charge of desiccant, two interlocked 4-way non-lubricated plug valves with double acting actuator, solenoid valve controls, 110 volt controls with control transformer, PLC, heater contactors, on-off switch, and a touch-screen operator interface for information on dryer status, sequence activity, alarms and maintenance information.

BAC-50 HYDROGEN DRYER

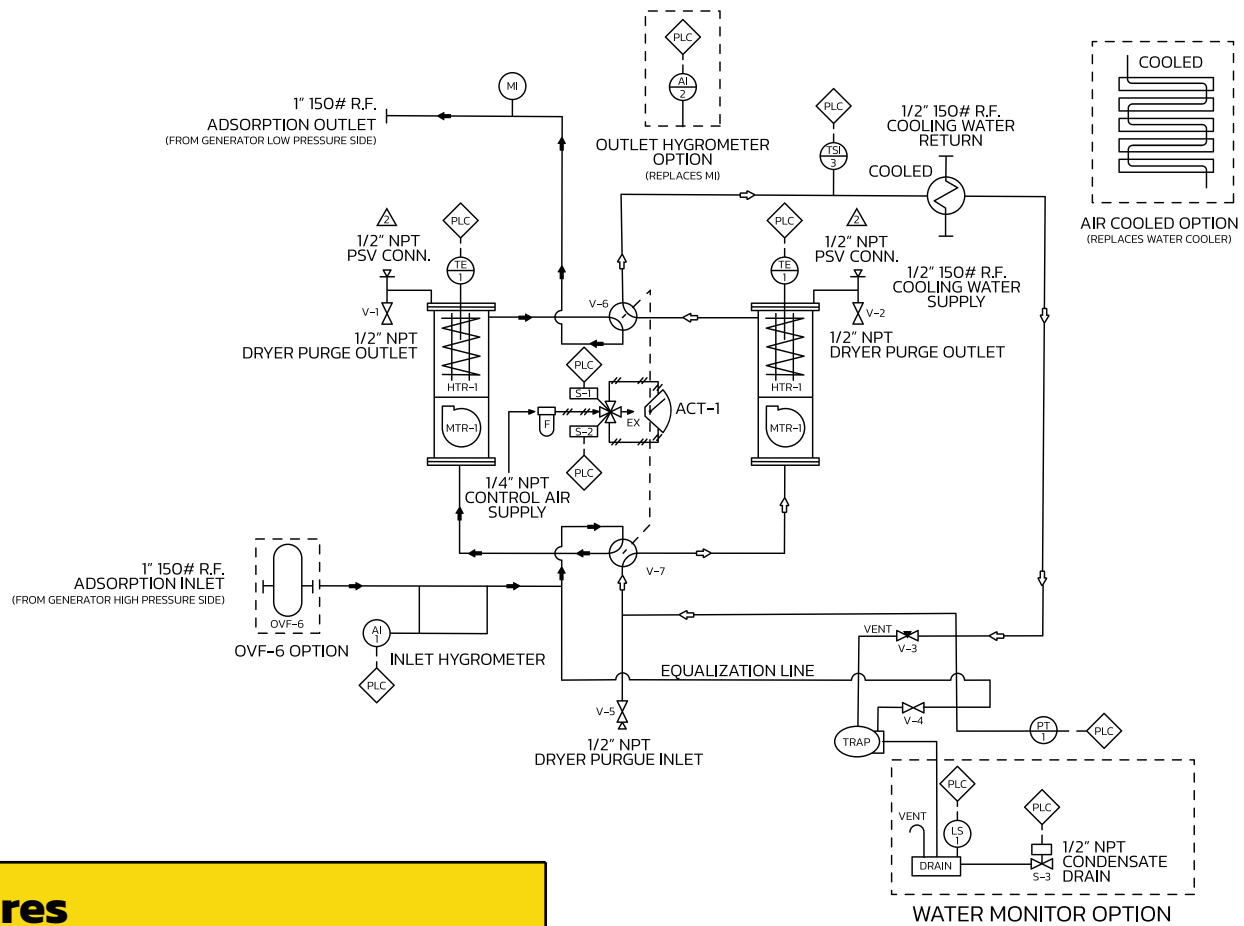

Features

- Inlet Dewpoint with 4–20 mA output and dual alarms
- Absolutely NO Hydrogen purging or venting
- Fully Automatic – No manual regeneration
- Integral Blowers – Maintain flow even during turning gear
- System per ASME B31.12 – for Hydrogen containing piping
- Closed Circuit Reactivation – with welded piping and stainless steel tubing
- Internal Heaters – Low watt density and efficient even heat distribution
- Flexible Data Logging – Analyze trends through Ethernet or SD Card
- Dual Tower Desiccant Beds – oversized for upset conditions, provide continuous drying
- Non-Lubricated Valves – no maintenance
- Electrical Enclosures – meet area requirements with a full PLC and touchscreen operator interface
- Protective Cage Enclosure – prevents tampering, protects operating personnel
- Over-Temperature Protection – extends heater life
- Approximate Weight:
1,800 pounds / 816 kgs
- Dimensions:
43”W x 36”D x 78”H / 110cms x 92cms x 199cms

Options

- Outlet Dewpoint Monitor
- Oil vapor pre-filter prevents contamination of desiccant
- Water Discharge Monitoring measures the water that is being removed from the generator
- Custom DCS communication available



Brochure Rev. 13



LECTRODRYER

135 Quality Drive
Richmond, Kentucky 40475
P.O. BOX 2500
Richmond, Kentucky
40476-2602

www.lectrodryer.com

Phone +1 (859) 624 2091
Fax +1 (859) 623 2436
USA Toll Free +1 (877) 403 5215